



© LAI GAMES
www.laigames.com

OPERATOR'S MANUAL



- ▶ READ THIS MANUAL BEFORE OPERATING THE MACHINE.
- ▶ KEEP THIS MANUAL FOR YOUR REFERENCE.

ISO 9001 CERTIFIED ORGANIZATION



ISO 9001: 2000 Cert No. 17460



LAI GAMES

Correspondence regarding this machine should be addressed to your closest **LAI GAMES** office, or **LAI GAMES** Distributor.
For contact details, refer to the back page of this manual.

DISCLAIMER

Please be aware that this software may not be legal to operate in some states and countries. We are providing this software and hardware to you on the understanding that you are installing it as per the regulatory requirements of your location and that you or your company is fully responsible for any legal problems that may arise from operating this version of software and hardware

© LAI GAMES

Copyright Notice:

Authorization is hereby provided to you to copy this manual in its entirety provided such copies are used for non-commercial purposes and solely for use with **LAI GAMES** products. This authorization is specifically conditioned to include all legends, copyright, proprietary and other notices which appear herein are unaltered on any and all copies you make.

sales@laigames.com www.laigames.com

LAI GAMES NOTES

Dear Customer,

Keep up-to-date with any new Software release or Service Bulletins for this Game.

Check our Website at www.laigames.com click on Product Support, here you find links to all the Bulletins and Software Updates to keep your game in top working Order.

Thanks,





TABLE OF CONTENTS

SPECIFICATIONS	2
CAUTION.....	4
INTRODUCTION	5
HOW TO PLAY	6
OPERATION	7
TEST MODE.....	8
SOUND, LAMPS AND DISPLAY TEST	9
SWITCH TEST	10
PROGRAMMABLE ADJUSTMENTS MODE	12
PROGRAMMABLE ADJUSTMENTS.....	13
QUICK REFERENCE TABLE.....	13
PROGRAMMABLE ADJUSTMENTS DETAILED.....	14
AUDITS MODE	17
GAME AUDITS QUICK REFERENCE TABLE.....	18
GAME AUDITS DETAILED	19
GAME HISTORY.....	<u>22</u>
GAME HISORY REFERENCE TABLE.....	<u>22</u>
ERRORS AND TROUBLESHOOTING.....	<u>24</u>
TROUBLESHOOTING GAME ERRORS.....	<u>25</u>
FUSE INFORMATION.....	<u>27</u>
FUSE LOCATION DIAGRAM.....	<u>28</u>



SECTION A: SERVICE INSTRUCTIONS.....	29
LOCATING AND ACCESSING PARTS	30
PARTS LOCATION DIAGRAM A	30
PARTS LOCATION DIAGRAM B.....	31
LAMPS	34
MAINTENANCE	3
SECTION B: TECHNICAL DETAILS.....	36
MAINS VOLTAGE ADJUSTMENT	37
3D PARTS BEE BEE BOPPIN.....	38
BEE BEE BOPPIN WIRING DIAGRAM	40



SAFETY PRECAUTIONS

The following safety precautions and advisories are used throughout this manual and are defined as follows.

*** WARNING! ***

Disregarding this text could result in serious injury.

*** CAUTION! ***

Disregarding this text could result in damage to the machine.

*** NOTE! ***

- An advisory text to hint or help understanding.



BE SURE TO READ THE FOLLOWING



*** WARNING! ***

Always turn **OFF** Mains AC power and unplug the game, before opening or replacing any parts.

Always when unplugging the game from an electrical outlet, grasp the plug, not the line cord.

Always connect the Game Cabinet to grounded electrical outlet with a securely connected ground line.

Do Not install the Game Cabinet outdoors or in areas of high humidity, direct water contact, dust, high heat or extreme cold.

Do Not install the Game Cabinet in areas that would present an obstacle in case of an emergency, i.e. near fire equipment or emergency exits.

*** CAUTION! ***

Always use a Digital Multimeter, logic tester or oscilloscope for testing integrated circuit (IC) logic PC boards. The use of a continuity tester is not permitted.

Do Not Connect or disconnect any of the integrated circuit (IC) logic PC boards while the power is **ON**.

Do Not use any fuse that does not meet the specified rating.

Do Not Subject the game cabinet to extreme temperature variations. Reliability of electrical components deteriorates rapidly over 60 °C.



MACHINE INSTALLATION and INSPECTION

When installing and inspecting “*Bee Bee Boppin*”, be very careful of the following points and pay attention to ensure that the players can enjoy the game safely.

- Be sure to turn the power **OFF** before working on the machine.

*** WARNING! ***

***Always** Turn **OFF** mains power before removing safety covers and refit all safety covers when work is completed.*

- Make sure the power cord is not exposed on the surface (floor, ground, etc.) where people walk through.
- Check that the rubber glide feet levelers are set evenly on the floor so that the game cabinet is unable to roll and is stable.
- Always make complete connections for the integrated circuit (IC) logic PC Boards and other connectors. Insufficient insertion can damage the electrical components.

*** CAUTION! ***

***Before** switching the machine on be sure to check that it has been set on the correct voltage for your area!*

***Refer** to the mains voltage adjustment section of this manual on page 37. Machines are normally shipped on 220V AC unless otherwise specified.*

- Only qualified personnel should inspect or test the integrated circuit (IC) logic PC Boards.
- If any integrated circuit (IC) logic PC Boards should need servicing. Please contact the nearest **LAI GAMES** distributor. (Refer to the back page of this manual)



SPECIFICATIONS

DIMENSIONS

- Weight: 136 kg (300lb)
- Height: 2008 mm (79.1")
- Width: 1070mm (42.1")
- Length: 1489mm (58.7")
- Power: Maximum 320 w – (220V @ 1.4A)(120V @ 2.6A)
Average 220 w – (220V @ 1.0A)(120V @ 1.9A)

ELECTRIC SUPPLY

- The game has the option to operate on a 120V, 220V, 240V AC 50/60Hz mains electric supply. **The supply must be a three wire grounded supply.**

*** NOTE: BEWARE!!!** Before switching the machine on be sure to check that it has been set on the correct voltage for your area!! Refer to the mains voltage adjustment section of this manual. Page 37. Machines are normally shipped on 220V AC unless otherwise specified.

LOCATION REQUIREMENTS

- Ambient temperature: between 5°C and 40°C.
- Ambient humidity: Low
- Ambient U.V. radiation: Very low
- Vibrations level: Low



CAUTION

DO NOT

Attempt to test the *logic boards* (PCBs) with ordinary test equipment as this may result in damage to digital components.

DO NOT

Connect or disconnect any of the logic boards' *integrated circuit modules* (ICs) while the power is **ON**.

- Mains AC power should always be turned OFF and the game unplugged, before replacing any parts.
- When unplugging the game from an electrical outlet, always grasp the plug, not the line cord.
- The Cabinet should be grounded with a securely connected ground line.

DO NOT

Subject the "*Bee Bee Boppin*" to extreme temperature variations. Reliability of electrical components deteriorates rapidly over 60 °C.

DO NOT

Expose the game logic boards to U.V. radiation (eg. direct sunlight) as this could eventually corrupt the program.

DO NOT

Install the Game Cabinet outdoors or in areas of high humidity, direct water contact, dust, high heat or extreme cold or in areas that would present an obstacle in case of an emergency, ie. near fire equipment or emergency exits, or an unstable surface or surface subject to floor or other vibration.



INTRODUCTION

CONGRATULATIONS! You have just bought “*Bee Bee Boppin*”. Another sensational product from LAI games. This game, based around the popular stomping game theme, is a significant step forward for this genre of games. With bright, friendly graphics, an exciting last 10 seconds panic mode and an ability to play an easy game or try a harder game for a chance at more tickets it is clearly a step ahead of other games. I hope you take the time to read this manual and learn about the many other features and user-friendly adjustments that can be made to “fine-tune” the game for maximum earning potential.

DESCRIPTION

- The “*Bee Bee Boppin*” is a one or more player, ticket redemption game, requiring players to stop on the buttons on the floor as the lights come on. Then in the last 10 seconds of each game all the lights come on and the player/s must quickly try to stomp them all out as quickly as possible.

PACKAGING

DELIVERY

- At delivery, the machine should arrive in good condition. To move the packaged machine for transport or placement, use a fork lift and take care not to hit the package or stack heavy objects on top, as this may cause damage to the machine.

CONTENTS

- “*Bee Bee Boppin*” game machine upright section
- “*Bee Bee Boppin*” game machine playfield section
- Keys: 1 × coin door key
 1 × back door key
 1 × ticket door key
- Operator’s manual
- IEC Power Cord (In cash box)



HOW TO PLAY

THE PLAYER’S AIM IS TO STAMP ON THE LIGHTS ON THE PLAYFIELD AS QUICKLY AND ACCURATLY AS POSSIBLE

- Insert coin/s.
- Press the Easy or Hard button to begin the game. Easy games allow a longer time to stamp out the lights, and the lights come on less rapidly. The hard game allows shorter time to “stomp” on the lights and more lights light up.
- As the lights under the buttons on the playfield come on, the player/s must “stomp” on the buttons quickly before they turn off again.
- If the player gets a button before it turns off, the “Hit” display increments. If the player does not stomp on the light before it turns off, the miss display is incremented
- At the end of the game, the tickets are dispensed according to the players % score, which is calculated by

$$\% = \frac{\text{Hit}}{\text{Hit} + \text{Miss}} \times 100$$



OPERATION

- The “*Bee Bee Boppin*” game has six operational modes: Attract mode, Play mode, Test Mode, Programmable Adjustments Mode, Audits Mode and Score History Mode.

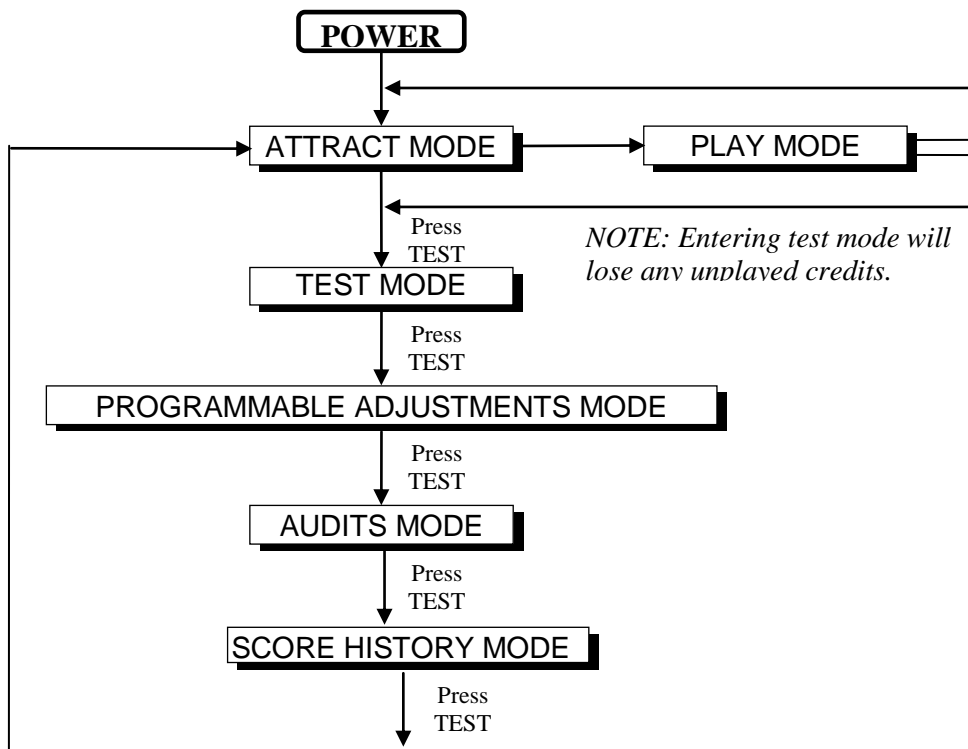

OPERATIONAL DIAGRAM

ATTRACT MODE

- The *Attract mode* provides a light and sound display and a demo game, while the game is unattended. This feature is to attract potential customers to play the game. The attract mode sound can be turned on and off (refer to programmable adjustment P08, page 12 of this manual).

PLAY MODE

- This game has two Play modes. The Standard *coin play* mode, where a coin, or coins are inserted. Or *free play* where no coins are necessary.

COIN PLAY

- The *Coin play* mode is entered from Attract mode, by inserting coins in any of the two coin slots on the front of the machine cabinet, then following the instructions in the “How to Play” section of this manual.

FREE PLAY

- The free play mode is entered from attract mode by holding the Service button for longer than five seconds [F] [L] [E] will be displayed on the 3-digit LED displays for approximately 5 seconds. Dispensing of tickets in free mode is disabled.

- To get back to normal game Play mode Switch Off and On the Machine.



TEST MODE

The Test mode has *two test configurations* allowing you to test the function of the Sound, button lamps & Credit Displays, the Game Switches, and other lamps. (Refer to Diagram below). Test mode can also be used for Clearing Game Errors, Setting Game Options and Checking Game Audits & Score History. (For Game Errors, refer to the Errors and Troubleshooting section of the manual page 24). Once test mode is entered, and if there is an active error, it's code will be displayed. To bypass or try to clear the error code, press the test button again.

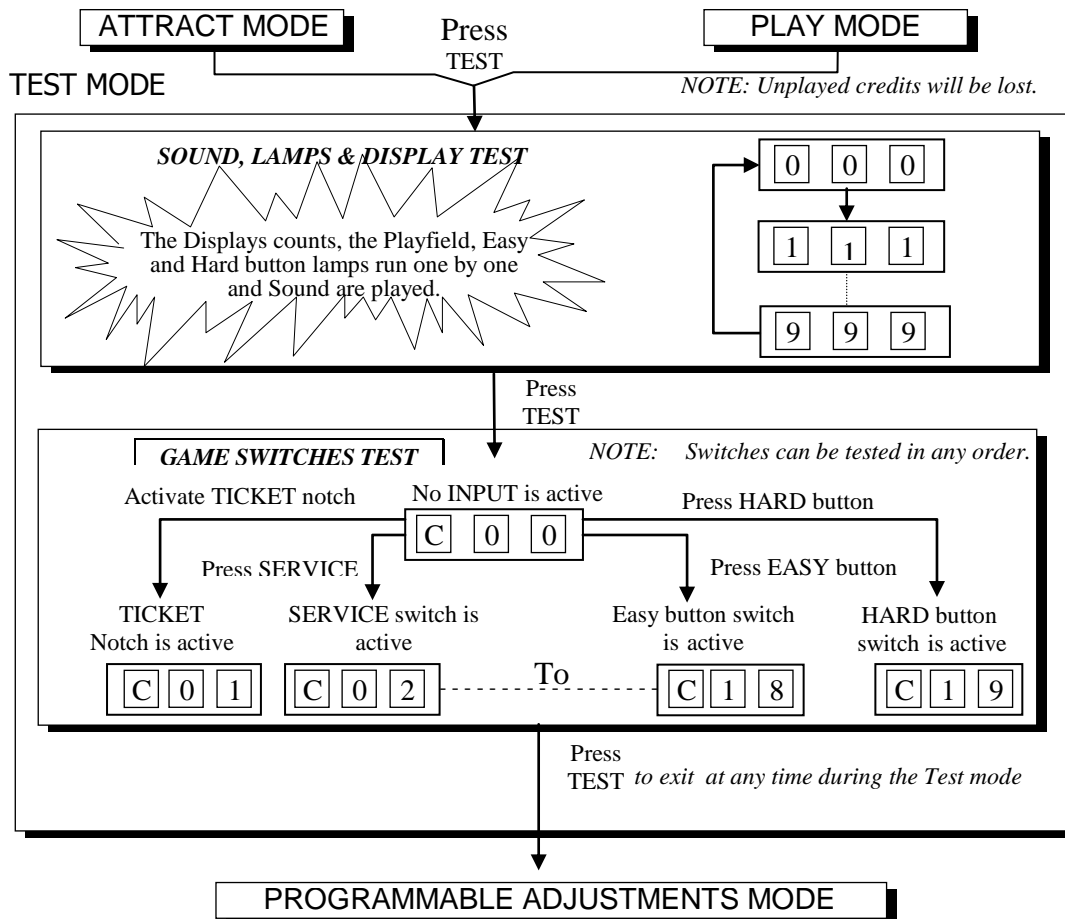

TEST MODE DIAGRAM

ADDITIONAL TEST BUTTON INFORMATION

- * The test button is also used for **DISPLAYING & CLEARING ERRORS**. For more information refer to Errors & Troubleshooting Page 23.
- * Entering Test Mode will **CLEAR** any **CREDITS** remaining in the game.
- * If during test mode no **ADJUSTMENTS** or actions are made to the game for approximately four minutes, it will automatically **RETURN** to Attract Mode.



SOUND, LAMPS AND DISPLAY TEST

- **ENTER** The Sound, Lamp & Display test is entered from Attract mode by pressing the test button once.

DURING THE TEST:

- ◆ Game music and voice over will be played.
 - ◆ The playfield button lamps will light up one by one.
 - ◆ The 3-digit displays will count from 000 to 999 and then repeat.
 - ◆ The Easy and Hard buttons will light up one by one
- **EXIT** The Sound, Lamp & Display test is exited by pressing the test button.
The next test will be switch test.



SWITCH TEST

■ **ENTER** The Switch Test can be entered by pressing the Test button once while in the Sound, Light & display test or by pressing the Test button twice while in Attract mode. will be displayed on the 3-digit display where 'XX' is the switches that are active.

■ **TESTING THE GAME SWITCHES**

- ◆ All game switches have a code from C1 to C19 as tabled below. By activating any of the switches, their code will be displayed on the 4-digit display. If no switches are active, will be displayed.

CODE	DISPLAY	MESSAGE DELIVERED	SWITCH LOCATION
C0	<input type="text" value="C"/> <input type="text" value="0"/> <input type="text" value="0"/>	No Input is active	
C1	<input type="text" value="C"/> <input type="text" value="0"/> <input type="text" value="1"/>	Ticket Notch	Ticket Door
C2	<input type="text" value="C"/> <input type="text" value="0"/> <input type="text" value="2"/>	Service Switch is active	Service Bracket
C4	<input type="text" value="C"/> <input type="text" value="0"/> <input type="text" value="4"/>	Coin Mech. 2 Switch Active	Coin Door
C5	<input type="text" value="C"/> <input type="text" value="0"/> <input type="text" value="5"/>	Coin Mech. 1 Switch Active	Coin Door
C11	<input type="text" value="C"/> <input type="text" value="1"/> <input type="text" value="1"/>	Game Button 1 Active	Lower Playfield
C12	<input type="text" value="C"/> <input type="text" value="1"/> <input type="text" value="2"/>	Game Button 2 Active	Lower Playfield
C13	<input type="text" value="C"/> <input type="text" value="1"/> <input type="text" value="3"/>	Game Button 3 Active	Lower Playfield
C14	<input type="text" value="C"/> <input type="text" value="1"/> <input type="text" value="4"/>	Game Button 4 Active	Lower Playfield
C15	<input type="text" value="C"/> <input type="text" value="1"/> <input type="text" value="5"/>	Game Button 5 Active	Lower Playfield
C16	<input type="text" value="C"/> <input type="text" value="1"/> <input type="text" value="6"/>	Game Button 6 Active	Lower Playfield
C17	<input type="text" value="C"/> <input type="text" value="1"/> <input type="text" value="7"/>	Game Button 7 Active	Lower Playfield
C18	<input type="text" value="C"/> <input type="text" value="1"/> <input type="text" value="8"/>	Easy Button Active	Instruction Panel
C19	<input type="text" value="C"/> <input type="text" value="1"/> <input type="text" value="9"/>	Hard Button Active	Instruction Panel

- ◆ Normal condition for the game is either:

- * indicating that no switches are active, or

- * indicating that the Ticket Notch is active



The Playfield Button switches are numbered as shown below:

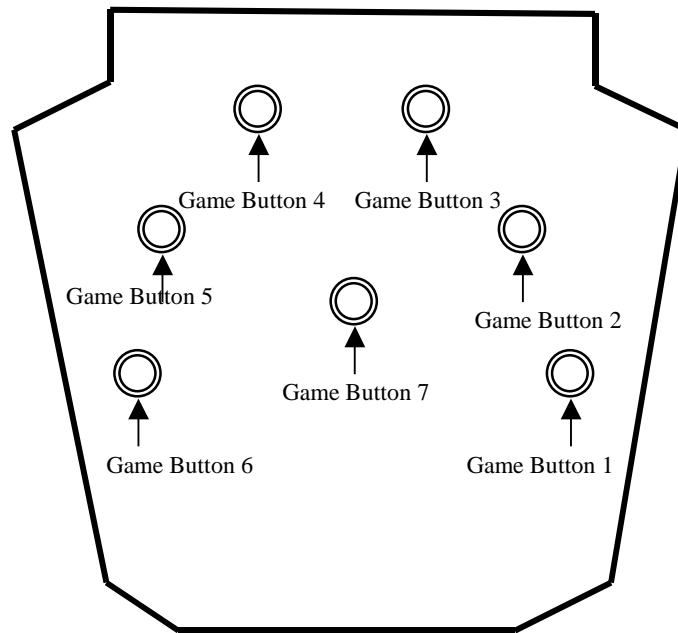

NOTE: Several switches can be simultaneously activated in Switch test. The display will then consecutively show their codes, indicating which switches are active. However, it is much easier to test the game switches individually.

- **EXIT** The Switch Test is exited into Programmable Adjustments Mode by pressing the Test Button once.

TICKET DISPENSER

The Ticket Notch switch (C1) can be activated either from the Ticket Feed button on the Ticket Dispenser PCB or by manually pushing the tickets from the ticket holder through the dispenser after releasing the ticket tension roller.

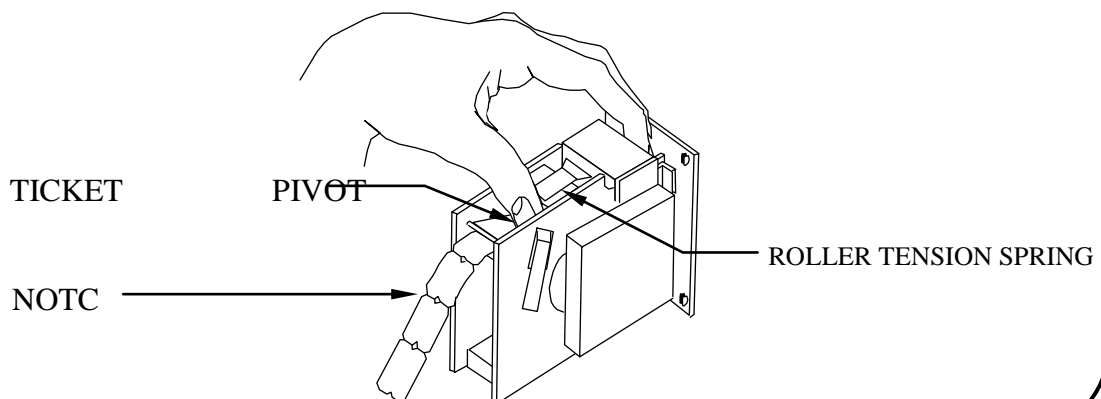



PROGRAMMABLE ADJUSTMENTS MODE

GAME ADJUSTMENTS

- ◆ The game has eighteen programmable adjustments that can be changed in this mode. They are P01 to P32 and their codes and values are displayed simultaneously during the adjustment procedure.

Example: displayed adjustment P 0 1 and its value 1.
Refer to the diagram below:

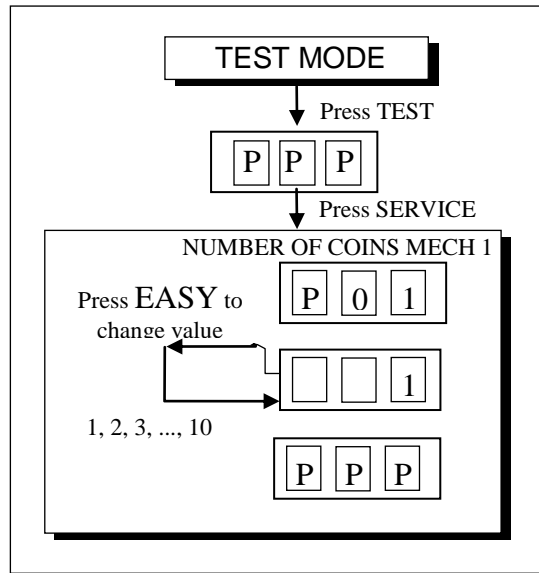

- ◆ There is a range of values for each variable of the game, and any value in this range can be chosen for the game settings, using the change procedure.

ADJUSTMENT PROCEDURE

- **ENTER** The Programmable Adjustments mode is entered from switch test by pressing the Test button once, or from Attract mode by pressing the Test button 3 times. This will prompt the code P P P on the upper display indicating the program mode.
- **SELECT** The Service button is pressed to step through each of the adjustment configurations, starting from the P 0 1 display, P01 being the first step, continuing through to P32, and then looping again from P01 to P32 until the mode is exited.
- **CHANGE** The Easy button is pressed to change the displayed value. The value can **ONLY** be stepped up by using the Easy button, but the value will loop back to its min value the next step after its max value.

* **NOTE:** Certain program adjustments have a fast adjustment feature. By holding the Start/Stop button down, the values step through quicker.

- **EXIT** The Programmable Adjustments mode is exited into Audits mode, by pressing the Test button once.



PROGRAMMABLE ADJUSTMENTS QUICK REFERENCE TABLE

CODE	PROGRAMMABLE ADJUSTMENTS	OPTIONAL VALUES	DEFAULT SETTINGS	FEATURES
P01	1 – 10	1, 2, 3...10	1	Coin Slot 1 – Coins / Credit
P02	1 – 10	1, 2, 3...10	1	Coin Slot 1 – Games / Credit
P03	0 – 10	0, 1, 2...10	0	Coin Slot 1 1 Bonus Credit every X coin
P04	1 – 10	1, 2, 3...10	1	Coin Slot 2 – Coins / Credit
P05	1 – 10	1, 2, 3...10	1	Coin Slot 2 – Games / Credit
P06	0 – 10	0, 1, 2...10	0	Coin Slot 2 1 Bonus Credit every X coin
P07	30 Sec –120 Sec	30, 35, 40...120	45	Game Time
P08	ON or OFF	ON or OFF	ON	Attract Sound ON / OFF
P17	0 –100 tickets	0, 1, 2, 3...100	3	Ticket won in EASY game Between 0% – 69%
P18	0 –100 tickets	0, 1, 2, 3...100	6	Ticket won in EASY game Between 70% – 89%
P19	0 –100 tickets	0, 1, 2, 3...100	8	Ticket won in EASY game Between 90% – 94%
P20	0 –100 tickets	0, 1, 2, 3...100	10	Ticket won in EASY game Between 95% –99 %
P21	0 –100 tickets	0, 1, 2, 3...100	12	Ticket won in EASY game At 100%
P28	0 –100 tickets	0, 1, 2, 3...100	3	Ticket won in HARD game Between 0% – 59%
P29	0 –100 tickets	0, 1, 2, 3...100	6	Ticket won in HARD game Between 60% – 79%
P30	0 –100 tickets	0, 1, 2, 3...100	8	Ticket won in HARD game Between 80% – 94%
P31	0 –100 tickets	0, 1, 2, 3...100	16	Ticket won in HARD game Between 95% – 99%
P32	0 –100 tickets	0, 1, 2, 3...100	20	Ticket won in HARD game At 100%



PROGRAMMABLE ADJUSTMENTS DETAILED.

■ P01=COIN MECH 1: NUMBER OF COINS PER CREDIT

(default 01) (Adjustable 1 – 10)

This variable sets the *number of coins* that need to be inserted into coin mechanism 1 for each credit. It can be set to either of 1, 2, 3... to 10 coins for one credit.

■ P02=COIN MECH 1: NUMBER of PLAYS PER CREDIT

(default 01) (Adjustable 1 – 10)

This sets the *number of games* for each credit from coin mechanism 1. It can be set to either of 1, 2, 3... to 10 plays for each credit.

■ P03=COIN MECH 1: NUMBER of COINS for BONUS CREDIT

(default 00) (Adjustable 0 – 10)

This variable sets the *number of coins* that need to be inserted in to coin mechanism 1 for one bonus credit. It can be set to either of 0, 1, 2... to 10 coins for one bonus credit, (0 = No Bonus).

■ P04=COIN MECH 2: NUMBER OF COINS PER CREDIT

(default 01) (Adjustable 1 – 10)

This variable sets the *number of coins* that need to be inserted into coin mechanism 2 for each credit. It can be set to either of 1, 2, 3... to 10 coins for one credit.

■ P05=COIN MECH 2: NUMBER of PLAYS PER CREDIT (default

01) (Adjustable 1 – 10)

This sets the *number of games* for each credit from coin mechanism 2. It can be set to either of 1, 2, 3... to 10 plays for each credit.

■ P06=COIN MECH 2: NUMBER of COINS for BONUS CREDIT

(default 00) (Adjustable 0 – 10)

This variable sets the *number of coins* that need to be inserted into coin mechanism 2 for one bonus credit. It can be set to either of 0, 1, 2... to 10 coins for one bonus credit, (0 = No Bonus).

■ P07=GAME TIME

(default 45 seconds) (Adjustable from 30 to 120 in 5 second steps)

This option allows the *number of seconds* each game runs for to be adjusted. This time does not include the time for the end of game feature.

* **NOTE:** The last 10 seconds of game play is “Panic Mode” (Where all the playfield lights come on and must be stomped on). This is regardless of the game time setting.



■ **P08=ATTRACT MODE SOUND**

(default ON) (Adjustable ON or OFF)

This adjustment turns the *attract mode sound* **ON** or **OFF**. This is the sound and music that the game generates to attract customers when it is not being played. The music will cycle approximately every 4 minutes.

■ **P17= TICKETS WON IN EASY GAME BETWEEN 0% AND 69%**

(default 3) (Adjustable from 0 to 100)

This setting is the *number of tickets* the game dispenses when a player who has played an EASY game finishes the game, with a percentage score of between 0% and 69% (inclusive).

■ **P18=TICKETS WON IN EASY GAME BETWEEN 70% AND 89%**

(default 6) (Adjustable from 0 to 100)

This setting is the *number of tickets* the game dispenses when a player who has played an EASY game finishes the game, with a percentage score of between 70% and 89% (inclusive).

■ **P19=TICKETS WON IN EASY GAME BETWEEN 90% AND 94%**

(default 8) (Adjustable from 0 to 100)

This setting is the *number of tickets* the game dispenses when a player who has played an EASY game finishes the game, with a percentage score of between 90% and 94% (inclusive).

■ **P20=TICKETS WON IN EASY GAME BETWEEN 95% AND 99%**

(default 10) (Adjustable from 0 to 100)

This setting is the *number of tickets* the game dispenses when a player who has played an EASY game finishes the game, with a percentage score of between 95% and 99% (inclusive).

■ **P21=TICKETS WON IN EASY GAME AT 100%**

(default 12) (Adjustable from 0 to 100)

This setting is the *number of tickets* the game dispenses when a player who has played an EASY game finishes the game, with a percentage score of 100%.

■ **P28=TICKETS WON IN HARD GAME BETWEEN 0% AND 59%**

(default 3) (Adjustable from 0 to 100)

This setting is the *number of tickets* the game dispenses when a player who has played an HARD game finishes the game, with a percentage score of between 0% and 59% (inclusive).



■ **P29=TICKETS WON IN EASY GAME BETWEEN 60% AND 79%**

(default 6) (Adjustable from 0 to 100)

This setting is the *number of tickets* the game dispenses when a player who has played an HARD game finishes the game, with a percentage score of between 60% and 79% (inclusive).

■ **P30=TICKETS WON IN HARD GAME BETWEEN 80% AND 94%**

(default 8) (Adjustable from 0 to 100)

This setting is the *number of tickets* the game dispenses when a player who has played an HARD game finishes the game, with a percentage score of between 80% and 94% (inclusive).

■ **P31=TICKETS WON IN HARD GAME BETWEEN 95% AND 99%**

(default 16) (Adjustable from 0 to 100)

This setting is the *number of tickets* the game dispenses when a player who has played an HARD game finishes the game, with a percentage score of between 95% and 99% (inclusive).

■ **P32=TICKETS WON IN HARD GAME AT 100%**

(default 20) (Adjustable from 0 to 100)

This setting is the *number of tickets* the game dispenses when a player who has played an EASY game finishes the game, with a percentage score of 100%.



AUDITS MODE

- By using the Audits Mode the operator can view statistics in all areas of the Game Play. This enables the operator to make calculated adjustments and “Fine Tune” the machine to maximize earning potential.

Example: displayed below is Audit number 1 and its value 2365.

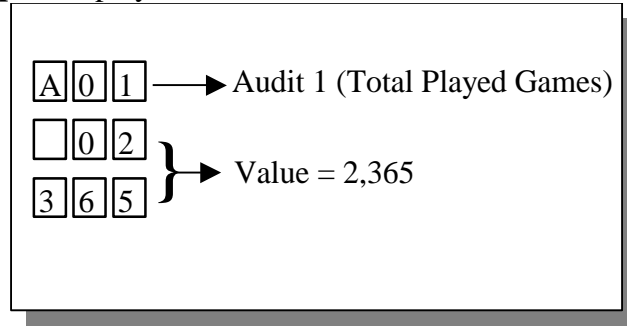

- The Audits mode allows bookkeeping of the games processed since the last game audits reset. While in this mode, the game audits can also be reset to zero (refer below).
- **ENTER** The Audits mode is entered from Programmable Adjustments mode by pressing the Test button once, or from Attract mode by pressing the Test button four times. This will prompt the **A A A** code on the display, indicating the Audits mode.
- **SELECT** The Service button is pressed for advancing each step through the set of audits configurations, starting from the **A A A** display with A1 and ending with A18, and then looping again from A1 to A18 until the mode is exited
- **RESET** The entire set of audits can be reset during any of the seven audit configurations, by holding the Easy button for longer than 5 seconds. The display will be cleared while still holding the button pressed and will return to the same audit step after releasing the button. The value of all audits will be reset to “00 000”.
- **EXIT** The Audits mode is exited into Score History mode, by pressing the Test Button.

*** NOTE:** ALL Audits will **STOP INCREMENTING** when the “Total Games Played”, audit A1, reaches 65535.

To restart the audits they must be reset to 00 000 by holding the Start/Stop button for longer than 5 seconds while in audits mode.



GAME AUDITS QUICK REFERENCE TABLE

DISPLAY	CODE	GAME AUDITS
A 0 1	A1	Total Played games
A 0 2	A2	Total coins in mechanism 1
A 0 3	A3	Total coins in mechanism 2
A 0 4	A4	Total games played in Easy mode
A 0 5	A5	Total games played in Hard mode
A 0 7	A7	Total games finished in Easy mode with a score between 0% and 69%
A 0 8	A8	Total games finished in Easy mode with a score between 70% and 89%
A 0 9	A9	Total games finished in Easy mode with a score between 90% and 94%
A 1 0	A10	Total games finished in Easy mode with a score between 95% and 99%
A 1 1	A11	Total games finished in Easy mode with a score of 100%
A 1 3	A13	Total games finished in Hard mode with a score between 0% and 59%
A 1 4	A14	Total games finished in Hard mode with a score between 60% and 79%
A 1 5	A15	Total games finished in Hard mode with a score between 80% and 94%
A 1 6	A16	Total games finished in Hard mode with a score between 95% and 99%
A 1 7	A17	Total games finished in Hard mode with a score of 100%
A 1 8	A18	Total service credits



GAME AUDITS DETAILED

■ A01 = TOTAL PLAYED GAMES

This Audit displays the *total number of Games* played on this machine since the audits were last cleared (including service games).

■ A02 = TOTAL COINS IN MECHANISM 1

This Audit displays the *total number of coins* inserted into coin mechanism 1 since the audits were last cleared.

■ A03 = TOTAL COINS IN MECHANISM 2

This Audit displays the *total number of coins* inserted into coin mechanism 2 since the audits were last cleared.

■ A04 = TOTAL GAMES PLAYED IN EASY MODE

This Audit displays the *total number of games* played in easy mode since the audits were last cleared. Easy mode is selected by the player pressing the “EASY” button on the control panel.

■ A05 = TOTAL GAMES PLAYED IN HARD MODE

This Audit displays the *total number of Games* played in hard mode since the audits were last cleared. Hard mode is selected by the player pressing the “HARD” button on the control panel.

■ A07 = TOTAL GAMES FINISHED IN EASY MODE WITH A SCORE BETWEEN 0 % AND 69%.

This Audit displays the *total number of Games* that were played in Easy mode with player receiving a final score between 0% and 69% inclusive since the audits were last cleared.

■ A08 = TOTAL GAMES FINISHED IN EASY MODE WITH A SCORE BETWEEN 70 % AND 89%.

This Audit displays the *total number of Games* that were played in Easy mode with player receiving a final score between 70% and 89% inclusive since the audits were last cleared.

■ A09 = TOTAL GAMES FINISHED IN EASY MODE WITH A SCORE BETWEEN 90 % AND 94%.

This Audit displays the *total number of Games* that were played in Easy mode with player receiving a final score between 90% and 94% inclusive since the audits were last cleared.



■ **A10 = TOTAL GAMES FINISHED IN EASY MODE WITH A SCORE BETWEEN 95 % AND 99%.**

This Audit displays the *total number of Games* that were played in Easy mode with player receiving a final score between 95% and 99% inclusive since the audits were last cleared.

■ **A11 = TOTAL GAMES FINISHED IN EASY MODE WITH A SCORE OF 100%.**

This Audit displays the *total number of Games* that were played in Easy mode with player receiving a final score of exactly 100% since the audits were last cleared.

■ **A13 = TOTAL GAMES FINISHED IN HARD MODE WITH A SCORE BETWEEN 0 % AND 59%.**

This Audit displays the *total number of Games* that were played in Hard mode with player receiving a final score between 0% and 59% inclusive since the audits were last cleared.

■ **A14 = TOTAL GAMES FINISHED IN HARD MODE WITH A SCORE BETWEEN 60 % AND 79%.**

This Audit displays the *total number of Games* that were played in Hard mode with player receiving a final score between 60% and 79% inclusive since the audits were last cleared.

■ **A15 = TOTAL GAMES FINISHED IN HARD MODE WITH A SCORE BETWEEN 80 % AND 94%.**

This Audit displays the *total number of Games* that were played in Hard mode with player receiving a final score between 80% and 94% inclusive since the audits were last cleared.

■ **A16 = TOTAL GAMES FINISHED IN HARD MODE WITH A SCORE BETWEEN 95 % AND 99%.**

This Audit displays the *total number of Games* that were played in Hard mode with player receiving a final score between 95% and 99% inclusive since the audits were last cleared.

■ **A17 = TOTAL GAMES FINISHED IN HARD MODE WITH A SCORE OF 100%.**

This Audit displays the *total number of Games* that were played in Hard mode with player receiving a final score of exactly 100% since the audits were last cleared.



■ **A18 = TOTAL SERVICE CREDITS.**

This Audit displays the *total number of service credits* that were used on the machine since the audits were last cleared.

*** NOTE! ***

- **ALL** Audits will **STOP INCREMENTING** when the “Total Number of Games Played”, audit A-07, reaches 60,000.
- To restart the audits they must be reset to 00 000 by holding the Start button for longer than 5 seconds while in audits mode.

*** NOTE! ***

- LAI Games Customer Support may request from the operator the values of these Manufacturers audits, to help with any service issues.



GAME HISTORY MODE

- By using the Score History Mode the operator can view the score, number of tickets won and whether the game was played in Easy or Hard mode for the last five games Played. This enables the operator to verify player win results.

- **ENTER** The Score History is entered from Audits Adjustments mode by pressing the Test button once, or from Attract mode by pressing the Test button five times. This will prompt the code on the display, indicating the Score History mode.

- **SELECT** The Service button is pressed for advancing each step through the set of Score History configurations, starting from the display with H1 and ending with H5, and then looping again from H1 to H5 until the mode is exited.

- **DISPLAY** For each of the Score History steps from H1 to H10, the game will display 2 separate audits. H1t, H2t, H3t and so on will show the number of tickets won in each game. The H1P, H2P, H3P and so on, will show final percentage score, and whether the game was played in Easy () or Hard () Mode.

- **EXIT** The Score History mode is exited into Attract mode, by pressing the Test Button once.

* **NOTE:** Score Histories will be erased if the game is switched off then on.
Empty Score Histories show as on the 3 digit Display.



GAME HISTORY QUICK REFERENCE TABLE

DISPLAY	CODE	GAME AUDITS
H 1 t	H1T	Most Recent Number of Tickets Won
H 1 P	H1P	Most Recent Percentage Score and Game Mode
H 2 t	H2T	Second Most Recent Number of Tickets Won
H 2 P	H2P	Second Most Recent Percentage Score and Game Mode
H 3 t	H3T	Third Most Recent Number of Tickets Won
H 3 P	H3P	Third Most Recent Percentage Score and Game Mode
H 4 t	H4T	Fourth Most Recent Number of Tickets Won
H 4 P	H4P	Fourth Most Recent Percentage Score and Game Mode
H 5 t	H5T	Fifth Most Recent Number of Tickets Won
H 5 P	H6P	Fifth Most Recent Percentage Score and Game Mode



ERRORS AND TROUBLESHOOTING

If the game microprocessor detects any problems with the operation of the game, an Error will be displayed on the 3-digit credit display and the machine will play a voice message. “Please Call Attendant”. Some error Messages will only be displayed when test mode is entered. Errors are displayed on the 3-digit display as E r X, where ‘X’ is the error number.

There are five error messages listed as follows:

CODE	ERROR DESCRIPTION	SOLUTION
Er1	TICKET ERROR Jammed tickets, no tickets or no ticket notch pulse for longer than 3 seconds.	Clear ticket jam or replenish tickets. After this, push Test button once to clear error.
Er3	EEPROM ERROR Problem with on-board EEPROM.	The main MCU is getting errors reading the EEPROM (24C16 IC on MCU).
Er4	PLAYFIELD BUTTON ACTIVE ERROR A Playfield button has been continually active for longer than 5 seconds	Check playfield button switches then repair/replace.
Er5	COIN SWITCH ACTIVE ERROR A coin switch has been continually active for more than 5 seconds.	Check coin mechanism switches then repair/replace.
Er6	PLAYFIELD BUTTON INACTIVE ERROR A playfield button has not been activated for more than 5 games in a row.	Check playfield button switches and harness/connectors then repair/replace.



TROUBLESHOOTING GAME ERRORS

■ CLEARING GAME ERRORS

Game errors can be cleared, by pushing the test button ONCE. The game will try and check if the error is fixed. If the reason for the error is fixed, the game will continue as normal. If the error is not fixed, the error will remain on the display.

■ Err1 – TICKET ERROR

This error usually occurs if the game has run out of tickets or there is a ticket jam when the machine tries to dispense tickets. A less common reason is if the game PCB tries to dispense tickets but doesn't get a notch pulse for approximately three seconds.

Use the Switch Test and test the notch pulse by manually activating the micro-switch on the ticket/capsule dispenser, an active notch will be display as **C1**, (See *Page 10 for Details*). If the game was out of tickets, replace the tickets, clear the jam and then push the test button once to clear the error. The game will then payout any owed tickets.

■ Err3 – EEPROM ERROR

This Error is only displayed in test mode and means that the CPU cannot read the EEPROM, or is receiving errors during communication with the EEPROM (The 24C16 IC on the main MCU PCB). This could cause problems with the game audits and program settings. The first thing to do is trying to switch ON and OFF the machine in at least 2 cycles, if message still appear than replace the EEPROM IC Atmel 24C16 on the CPU PCB with the new EEPROM, If still Error message, this could be a problems with the game audits and program. If this error occurs, send your main MCU PCB to the nearest authorized LAI games dealer for repair.

■ Err4 – PLAYFIELD BUTTON ACTIVE ERROR

This Error is a soft error, which means it will not stop the customers from playing the game. The error indicates that a button on the playfield has been continually active for more than 5 seconds. If this occurs when no one is depressing a button, then it is likely a switch for that button is jammed. Use game switch test mode to determine which button is jammed and repair/replace the faulty switch.

■ Err5 – COIN SWITCH ERROR

This Error is displayed when a coin input has been active continually for 5 seconds or longer. The problem is likely due to a stuck coin switch or someone trying to 'string' a coin. Enter switch mode to check with coin switch is active and check the micro-switch on the appropriate coin switch.



■ **Err6 – PLAYFIELD BUTTON IN ACTIVE ERROR**

This Error is a soft error, which means it will not stop the customers from playing the game. The error indicates that a button on the playfield has not been activated for more than 5 games in a row. This can occur during testing of the machine if many games are played with out the buttons being pressed, or can be due to a broken button on the playfield. Use the game switch test mode to determine which button is faulty and repair/replace the faulty switch.



FUSE INFORMATION

MAIN AC SUPPLY FUSE (1 x 6 AMP FAST BLOW)

This fuse is for the main AC supply and is situated in the IEC mains input socket.

*** NOTE:** The power cord must be removed before the fuse can be accessed.

MCU POWER FUSE (1 x 1.5AMP FAST BLOW)

The fuse is for the supply to the MCU PCB.

DC DRIVER FUSES (2 x 5AMP FAST BLOW)

These two fuses are for all the DC controlled motors, counters and lamps. These include the motor of the ticket mechanism, the coin and ticket counters, the playfield lamps and also the level display lamps.



FUSE LOCATION DIAGRAM

As viewed from rear

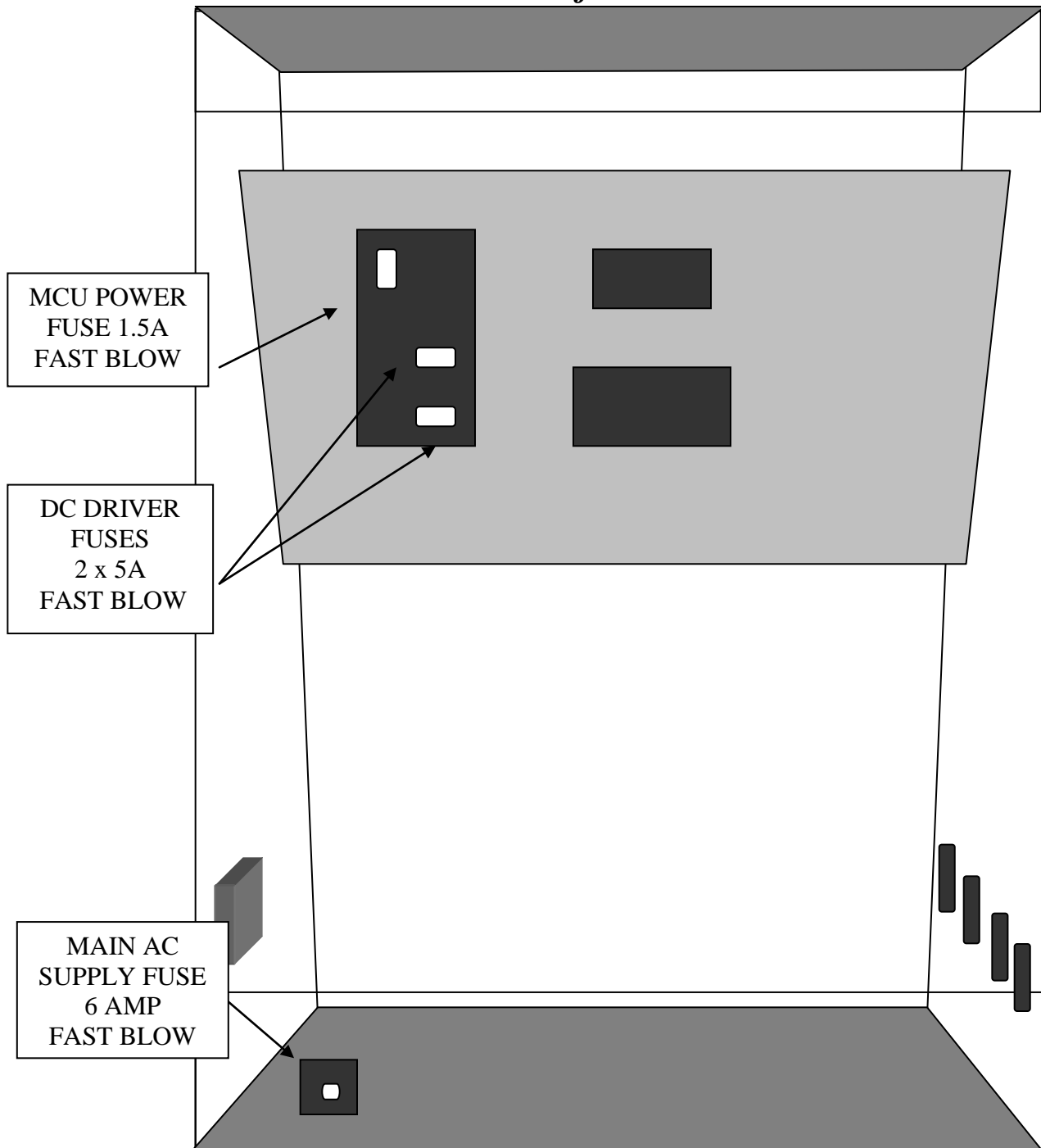



SECTION A: SERVICE INSTRUCTIONS

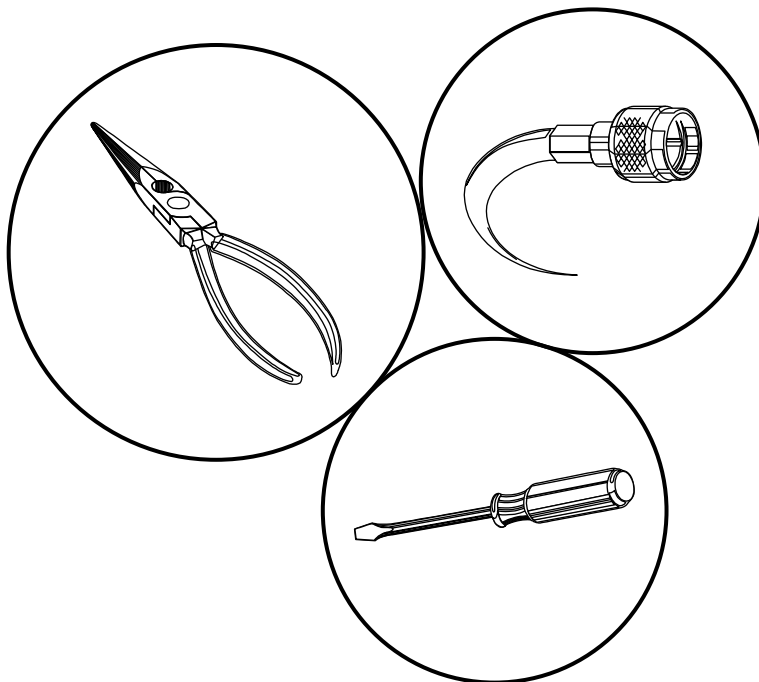

 **BE SURE TO READ THE FOLLOWING** 
Carefully before servicing this machine



A



LOCATING AND ACCESSING PARTS

PARTS LOCATION DIAGRAM A

As viewed from rear

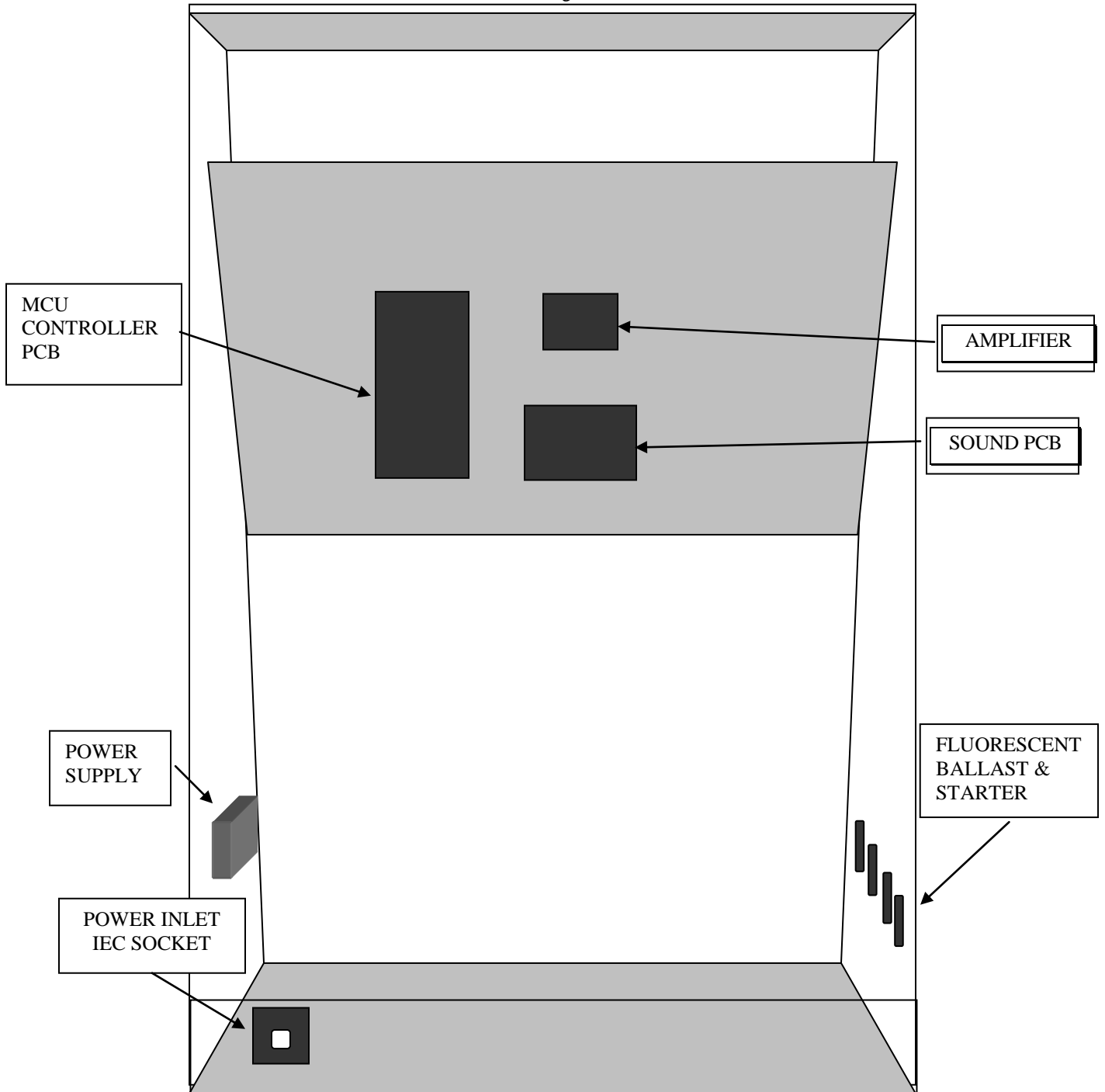



PARTS LOCATION DIAGRAM B

As viewed from rear

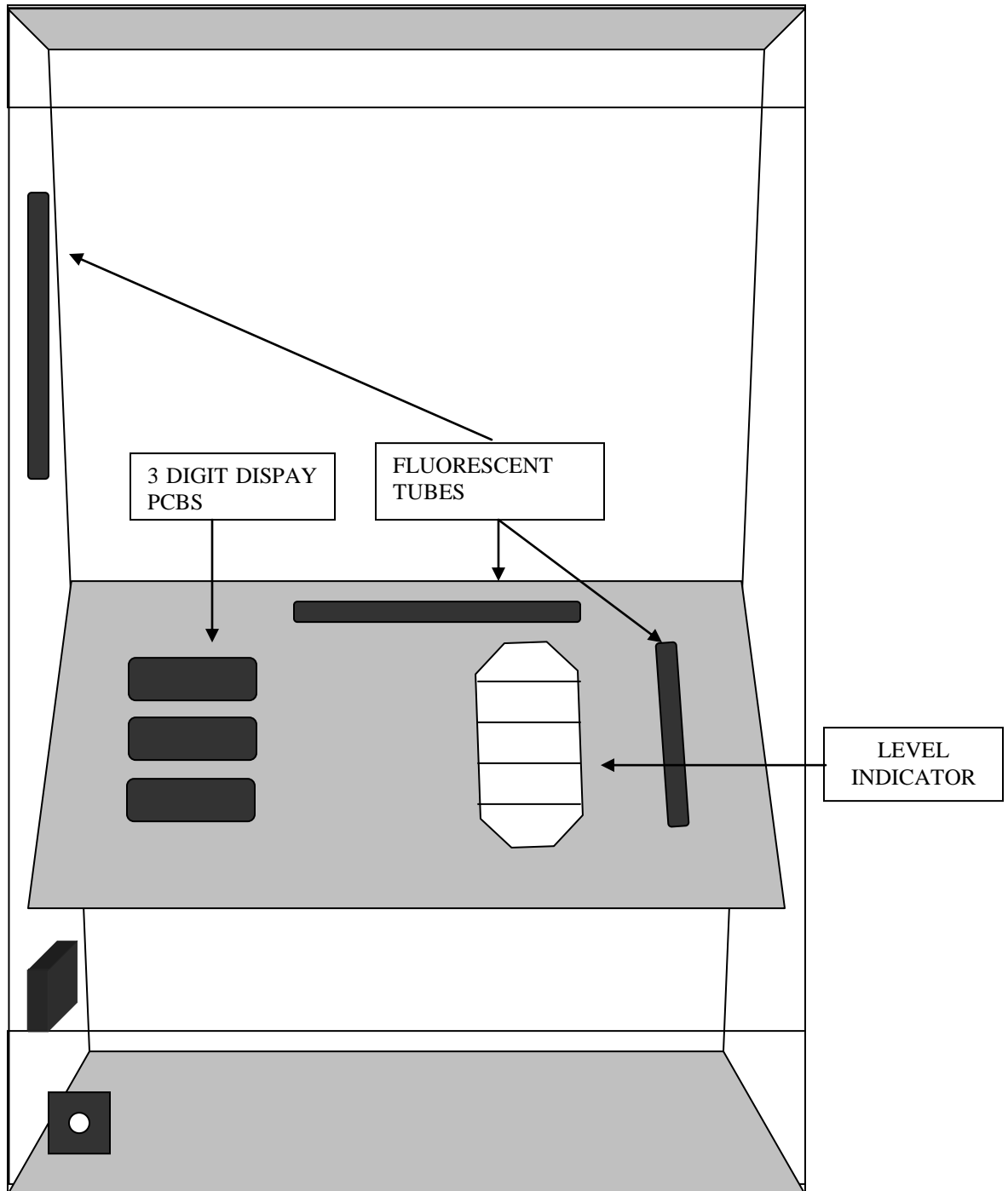



POWER CORD

- The power cord is a standard IEC power cord (as used on computers) that is plugged in to the power inlet socket at the rear of the machine. The power cord can be removed for transport.

COIN MECHANISM

- The coin mechanism can be accessed inside the front door in the center of the machine cabinet.

CASH BOX

- The cash box is located inside the front door in the center of the machine cabinet.

GAME CONTROLS

EASY and HARD BUTTONS

- ◆ EASY BUTTON: The easy button is the green button on the right hand side of the control panel. This button is used to start the game in easy play mode.
- ◆ HARD BUTTON: The easy button is the red button on the right hand side of the control panel. This button is used to start the game in hard play mode

SERVICE controls, located on the service bracket mounted on top of the cash box.

- ◆ SERVICE BUTTON: Used to input credits to the game without activating the coin counter, and to perform test procedures in combination with the test button.
- ◆ TEST BUTTON: Used to perform the test mode, in combination with the Service button.
- ◆ VOLUME KNOB: Used to adjust the speaker's sound level.





POWER INLET

- The power inlet is located at the rear of the machine on the Left-hand side as viewed from the rear. It is a standard IEC inlet socket.

MAINS SWITCH

- The mains switch is located on the power inlet assembly along with the mains fuse, and IEC inlet socket.

FUSES

- For location of all fuses refer to Fuses and Fuse location, page 28 of this manual.

*** WARNING! ***

*Turn OFF mains power before attempting to change fuses.
Always use the correct rated fuse. Refer to page 28 for fuse information.*

POWER SUPPLY

- The power supply is located on the base of the cabinet and is accessed from the rear of the machine. It is a 12V 13A switching power supply.

SPEAKERS

- Two speakers are located on the left and right side of the main cabinet. Access is from the rear of the machine.

PCB's

- For location of all game PCB's, refer to the Parts Location diagram page 1 of this manual.
- **TICKET DISPENSER:** This is installed behind the main door in center of the main cabinet.



LAMPS

*** NOTE:** Before replacing any lamps always unplug the machine from the mains supply and only replace with the same or equivalent lamp.

- **LEVEL INDICATOR LAMPS, EASY AND HARD LAMPS:** There are 5 groups of lamps in the level indicator and 1 lamp each in the easy and hard buttons (GE908). They are all 12V/DC and driven by the main MCU PCB.
- **MAIN PLAYFIELD LAMPS:** These are 12V/DC lamps, one for each button on the main playfield with a bayonet type connector (GE89). They are driven from the main MCU PCB.
- **COIN CHUTE LAMP:** These are 12V/DC lamps, one for each coin chute.
- **FLUORESCENT NEON'S:** These are installed behind the main display artwork and are accessed from the rear of the machine. Ballasts installed in the base of the machine drive all these neon's.



MAINTENANCE

CLEANING AND CHECK UP

*** NOTE:** Do not use solvents on the panels as it may affect the artwork.

■ EXTERIOR

Dust regularly and clean the external cabinet areas as required, using a soft water-damp cloth and mild soap. Check for blown bulbs and replace as required.

- ◆ Any scratches or marks in the glass can be buffed out using car polish or cut and polish.

■ INTERIOR

*** CAUTION! ***

*Make sure to turn power OFF or pull cord from outlet before cleaning the interior of the machine.
After cleaning the cabinet interior, check all harness connectors and restore all loose or interrupted connections.*

- ◆ Regularly dust and vacuum the interior of the cabinet, taking care to remove any objects that may have fallen on the PCBs. Check and tighten all fixing hardware and fasteners as required.
- ◆ Regularly check the operation of the playfield buttons using the using the switch test (page 10).



SECTION B: TECHNICAL DETAILS

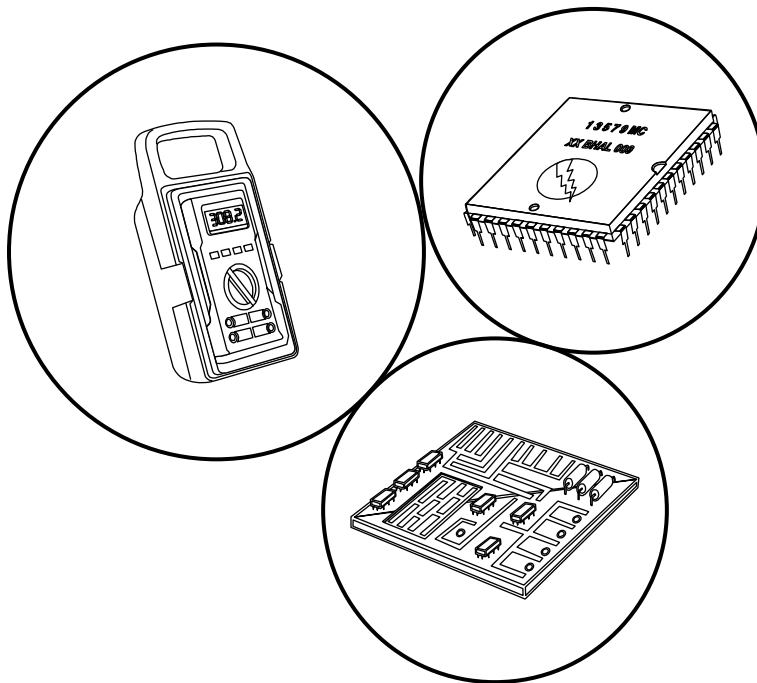

It is advised that anybody using SECTION B for repairing or modifying any of the components of the game should be a qualified technician, having at least a basic knowledge of digital components, integrated circuits and electricity.



B



MAINS VOLTAGE ADJUSTMENT

POWER SUPPLY

- The Switch Mode Power Supply has a switch to set the mains voltage range. It is located at the rear of the game cabinet, and is accessed via the front door. Use a thin blade screwdriver to move the selector switch to the desired mains voltage (See Diagram Below)

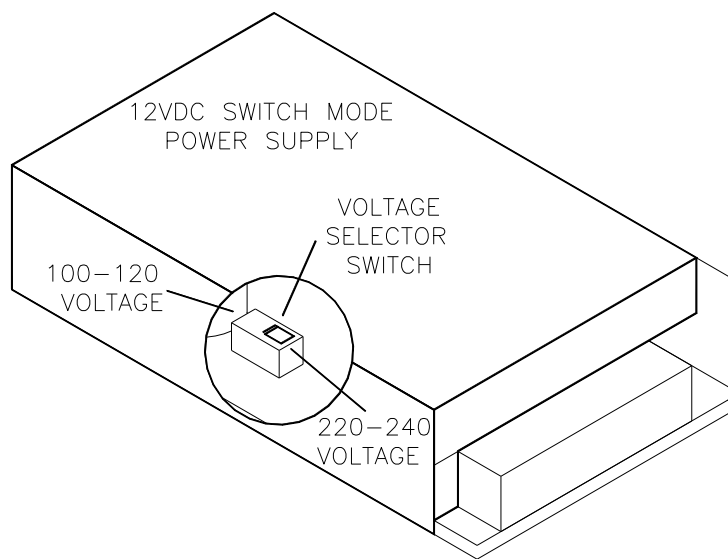



3D PARTS BEE BEE BOPPIN

Bee Bee Boppin

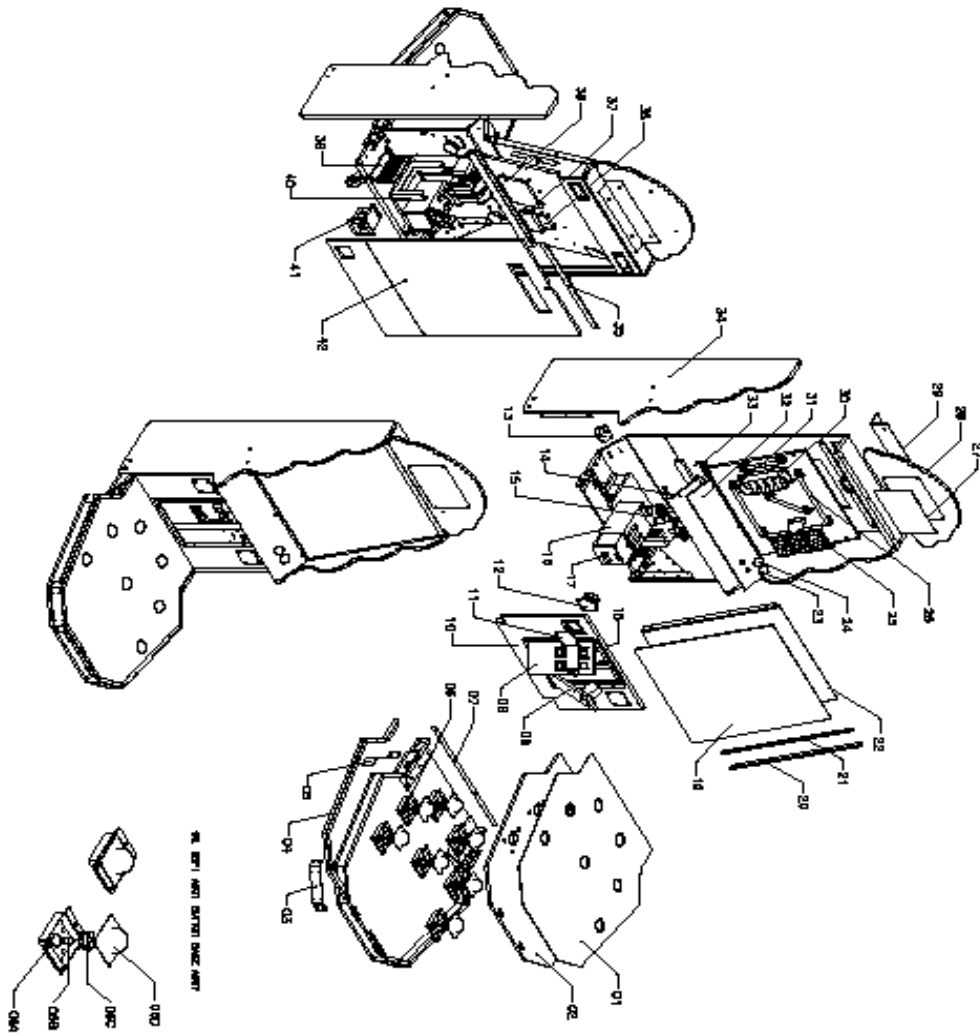

NO	PART NO	DESCRIPTION	QTY
1	800-79-401-01	EXTERNAL MACHINERY PROTECTION	1
2	800-79-412-01	REAR PANEL	1
3	800-79-411-01	REAR PANEL PLATED	1
4	800-79-401-01	COIN SLOT	1
5	800-79-401-01	COIN SLOT	1
6	800-79-411-01	COIN SLOT	1
7	800-79-401-01	COIN SLOT	1
8	800-79-401-01	COIN SLOT	1
9	800-79-401-01	COIN SLOT	1
10	800-79-401-01	COIN SLOT	1
11	800-79-401-01	COIN SLOT	1
12	800-79-401-01	COIN SLOT	1
13	800-79-401-01	COIN SLOT	1
14	800-79-401-01	COIN SLOT	1
15	800-79-401-01	COIN SLOT	1
16	800-79-401-01	COIN SLOT	1
17	800-79-401-01	COIN SLOT	1
18	800-79-401-01	COIN SLOT	1
19	800-79-401-01	COIN SLOT	1
20	800-79-401-01	COIN SLOT	1
21	800-79-401-01	COIN SLOT	1
22	800-79-401-01	COIN SLOT	1
23	800-79-401-01	COIN SLOT	1
24	800-79-401-01	COIN SLOT	1
25	800-79-401-01	COIN SLOT	1
26	800-79-401-01	COIN SLOT	1
27	800-79-401-01	COIN SLOT	1
28	800-79-401-01	COIN SLOT	1
29	800-79-401-01	COIN SLOT	1
30	800-79-401-01	COIN SLOT	1
31	800-79-401-01	COIN SLOT	1
32	800-79-401-01	COIN SLOT	1
33	800-79-401-01	COIN SLOT	1
34	800-79-401-01	COIN SLOT	1
35	800-79-401-01	COIN SLOT	1
36	800-79-401-01	COIN SLOT	1
37	800-79-401-01	COIN SLOT	1
38	800-79-401-01	COIN SLOT	1
39	800-79-401-01	COIN SLOT	1
40	800-79-401-01	COIN SLOT	1
41	800-79-401-01	COIN SLOT	1
42	800-79-401-01	COIN SLOT	1
43	800-79-401-01	COIN SLOT	1
44	800-79-401-01	COIN SLOT	1
45	800-79-401-01	COIN SLOT	1
46	800-79-401-01	COIN SLOT	1
47	800-79-401-01	COIN SLOT	1
48	800-79-401-01	COIN SLOT	1
49	800-79-401-01	COIN SLOT	1
50	800-79-401-01	COIN SLOT	1
51	800-79-401-01	COIN SLOT	1
52	800-79-401-01	COIN SLOT	1
53	800-79-401-01	COIN SLOT	1
54	800-79-401-01	COIN SLOT	1
55	800-79-401-01	COIN SLOT	1
56	800-79-401-01	COIN SLOT	1
57	800-79-401-01	COIN SLOT	1
58	800-79-401-01	COIN SLOT	1
59	800-79-401-01	COIN SLOT	1
60	800-79-401-01	COIN SLOT	1
61	800-79-401-01	COIN SLOT	1
62	800-79-401-01	COIN SLOT	1
63	800-79-401-01	COIN SLOT	1
64	800-79-401-01	COIN SLOT	1
65	800-79-401-01	COIN SLOT	1
66	800-79-401-01	COIN SLOT	1
67	800-79-401-01	COIN SLOT	1
68	800-79-401-01	COIN SLOT	1
69	800-79-401-01	COIN SLOT	1
70	800-79-401-01	COIN SLOT	1
71	800-79-401-01	COIN SLOT	1
72	800-79-401-01	COIN SLOT	1
73	800-79-401-01	COIN SLOT	1
74	800-79-401-01	COIN SLOT	1
75	800-79-401-01	COIN SLOT	1
76	800-79-401-01	COIN SLOT	1
77	800-79-401-01	COIN SLOT	1
78	800-79-401-01	COIN SLOT	1
79	800-79-401-01	COIN SLOT	1
80	800-79-401-01	COIN SLOT	1
81	800-79-401-01	COIN SLOT	1
82	800-79-401-01	COIN SLOT	1
83	800-79-401-01	COIN SLOT	1
84	800-79-401-01	COIN SLOT	1
85	800-79-401-01	COIN SLOT	1
86	800-79-401-01	COIN SLOT	1
87	800-79-401-01	COIN SLOT	1
88	800-79-401-01	COIN SLOT	1
89	800-79-401-01	COIN SLOT	1
90	800-79-401-01	COIN SLOT	1
91	800-79-401-01	COIN SLOT	1
92	800-79-401-01	COIN SLOT	1
93	800-79-401-01	COIN SLOT	1
94	800-79-401-01	COIN SLOT	1
95	800-79-401-01	COIN SLOT	1
96	800-79-401-01	COIN SLOT	1
97	800-79-401-01	COIN SLOT	1
98	800-79-401-01	COIN SLOT	1
99	800-79-401-01	COIN SLOT	1
100	800-79-401-01	COIN SLOT	1



Bee Bee Boppin

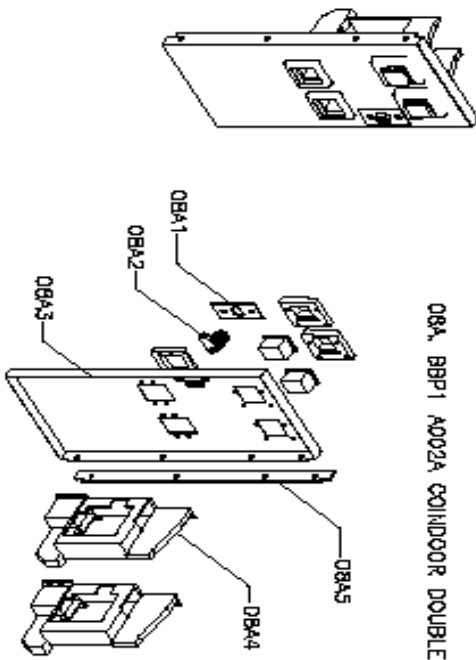

08A, BBP1 A002A COINDOOR DOUBLE

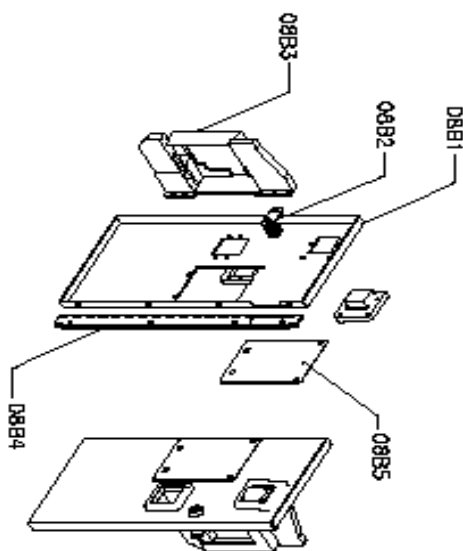

08B, BBP1 A002B 1 DBA 1 COINDOOR

NO	PART NO	DESCRIPTION	QTY
08A	BBP1 A002A	COINDOOR DOUBLE	1
DBA1	BBP1-FM-053-RD	THANDLE COVER	1
DBA2	HM0004	KEY LOCK ANGLE	1
DBA3	BBP1-FM-04B-RD	COINDOOR DOUBLE	1
DBA4	HA0014	COIN MECHANISM HOLDER ASSY	1
DBA5	BBP1-FM-017-RD	COINDOOR DOUBLE HINGE	1
08B	BBP1 A002B	1 DBA 1 COINDOOR	1
DBB1	BBP1-FM-054-RD	COINDOOR DBA	1
DBB2	HM0004	KEY LOCK ANGLE	1
DBB3	HA0014	COIN MECHANISM HOLDER ASSY	1
DBB4	BBP1-FM-017-RD	COINDOOR DOUBLE HINGE	1
DBB5	BBP1-FM-055-RD	DBA COVER	1
09	BBP1 A003	TICKET DOOR ASSEMBLY	1
DBA	HM0004	KEY LOCK ANGLE	1
DBB	BBP1-FM-04D-RD	TICKET DOOR	1
DBC	EA1102	TICKET DISPENSER ENTROPY	1
DBD	BBP1-FM-033-RD	TICKET DOOR HINGE	1

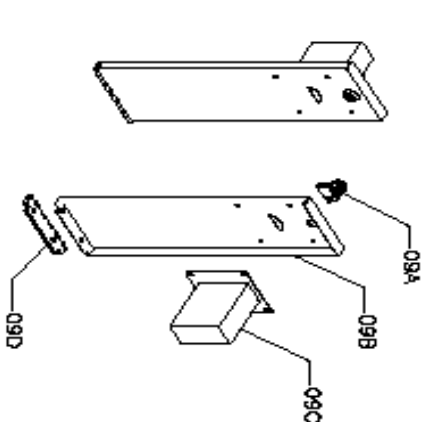

09, BBP ADD1 TICKET DOOR

BEE BEE BOPPIN WIRING DIAGRAM

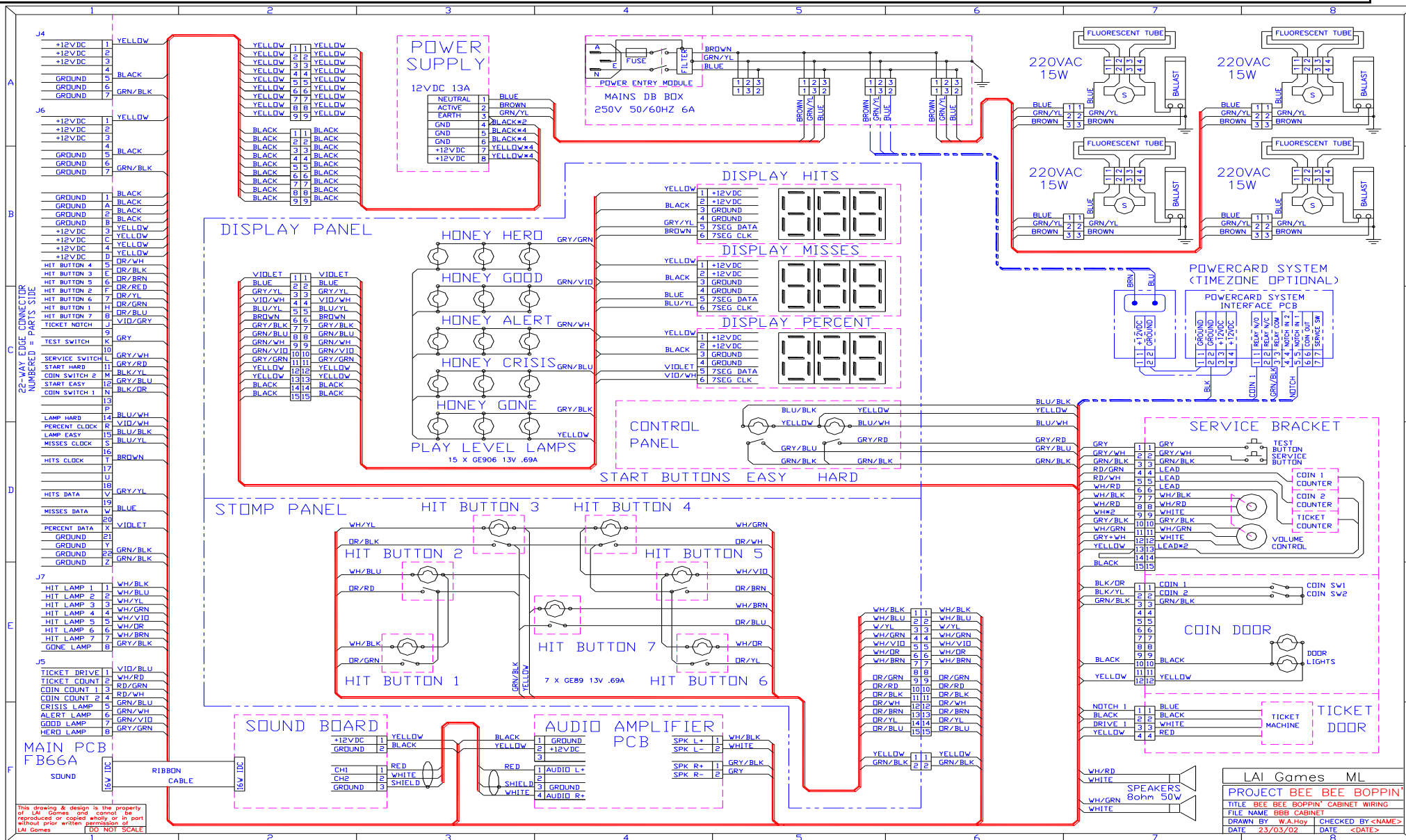

WARRANTY

LAI GAMES warrants its manufactured products for a period of 3 months inclusive of parts and labor from the date of sale.

LAI GAMES exclusive obligation is to repair any item with any defects as a result of faulty workmanship or materials, providing the defective item or items of equipment are returned to the **LAI GAMES** distributor from which the machine was purchased.

LAI GAMES shall have no obligation to make repairs necessitated by negligence or interference to any component by any unauthorized personal. This will automatically void any existing warranty.

IF MAKING A WARRANTY CLAIM:

- (a) A Copy of the sales invoice must accompany the claim.
- (b) To and from Transport and freight costs are not covered by the warranty.
- (c) Warranty is not transferable with the sale of a machine from one owner to another.



LAI GAMES

sales@laigames.com

www.laigames.com



INTERNATIONAL SALES & SERVICE

Sales/Enquires: sales@laigames.com

Product Support: support@mleisure.co.id

Web site: www.laigames.com



ISO 9001 CERTIFIED ORGANIZATION



ISO 9001: 2000 Cert No. 17460